

SCAG[®]

POWER EQUIPMENT

MODEL GC-STC

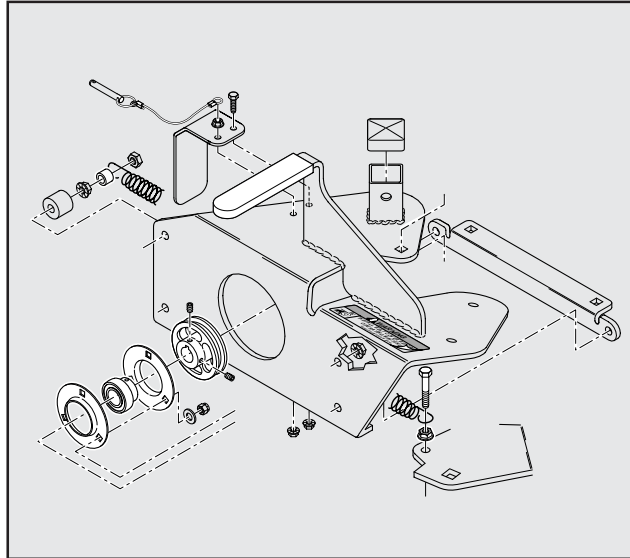

THIS MANUAL CONTAINS THE OPERATING INSTRUCTIONS AND SAFETY INFORMATION FOR YOUR SCAG ACCESSORY. READING THIS MANUAL WILL PROVIDE YOU WITH MAINTENANCE AND ADJUSTMENT PROCEDURES TO KEEP YOUR ACCESSORY PERFORMING TO MAXIMUM EFFICIENCY. THE SPECIFIC MODELS THAT THIS BOOK COVERS ARE CONTAINED ON THE INSIDE COVER. BEFORE OPERATING YOUR MACHINE, PLEASE READ ALL THE INFORMATION ENCLOSED.

OPERATOR'S MANUAL



WARNING

FAILURE TO FOLLOW SAFE OPERATING PRACTICES MAY RESULT IN SERIOUS INJURY.

- * Keep all safety shields in place.
- * Before performing any maintenance or service, stop the machine and remove the spark plug wire.
- * If a mechanism becomes clogged, stop the engine before cleaning.
- * Keep hands, feet and clothing away from power-driven parts.
- * Read this manual completely as well as the Operator's Manual that came with your mower.
- * Keep others off the tractor (only one person at a time).

REMEMBER - YOUR MOWER IS ONLY AS SAFE AS THE OPERATOR!

Hazard control and accident prevention are dependent upon the awareness, concern, prudence, and proper training of the personnel involved in the operation, transport, maintenance, and storage of the equipment.

This manual covers the operating instructions
and illustrated parts list for:

GC-STC with a part number of 9015

1.1 INTRODUCTION

This manual has been prepared to provide the information you need to correctly assemble, operate, and maintain this grass catcher. Read it carefully and keep it for future reference.

The replacement of any part on this product by other than the manufacturer's authorized replacement part may adversely affect the performance, durability or safety of this product.

USE OF OTHER THAN ORIGINAL SCAG REPLACEMENT PARTS WILL VOID THE WARRANTY.

If additional information or service is needed that is not outlined in this manual, please contact your Scag Power Equipment dealer. Scag dealers are trained in the latest service methods and carry a full line of Scag replacement parts.

When ordering parts, always provide the complete model number of your catcher.

All information provided in this manual is based upon information available at the time of printing. Scag Power Equipment reserves the right to make changes at any time without notice or obligation.

1.2 DIRECTION REFERENCE

The "Right" and "Left", "Front" and "Rear" of the machine are referenced from the normal operating position.

2.1 SAFETY AND OPERATING INSTRUCTIONS

-Note-

To avoid personal injury, it is imperative that all safety instructions be observed.

1. **Read this operator's manual and the operator's manual that is supplied with the machine this attachment is used on.**

A replacement manual is available from your authorized Scag Service Dealer or by contacting: Scag Power Equipment, Service Department at P.O. Box 152, Mayville, WI 53050. You may also contact us through our website at www.scag.com Please indicate the complete model and number of your Scag product when ordering a replacement manual.



2. Before removing the grass bags, disengage the mower, stop the engine and wait for all movement to stop.
3. **ALWAYS** turn the engine **OFF**, remove the key and wait for all movement to stop before servicing or cleaning the mower or the grass catcher.
4. Do not modify or alter any component of the grass catcher attachment or mower.
5. Do not allow any passengers to ride on the grass catcher attachment or on the mower.

3.1 ASSEMBLY INSTRUCTIONS

-NOTE-

Use the illustrated parts list as a part number reference when following the assembly instructions.

1. Remove all packaging materials. Lay out the mounting hardware and the catcher assembly parts for easy access. Prepare the work area making sure that it is a clean, safe environment.



2. Remove the discharge chute from the cutter deck. See Figure 1.

-NOTE-

Do not discard the discharge chute or mounting hardware. The discharge chute MUST be reinstalled anytime the grass catcher has been removed from the machine.

3. Remove the right side belt cover to gain access to the spindle assembly. Remove the front u-nut from the cutter deck bracket. See Figure 1.

-NOTE-

Retain the original belt cover. This cover MUST be reinstalled anytime the complete catcher system is removed.

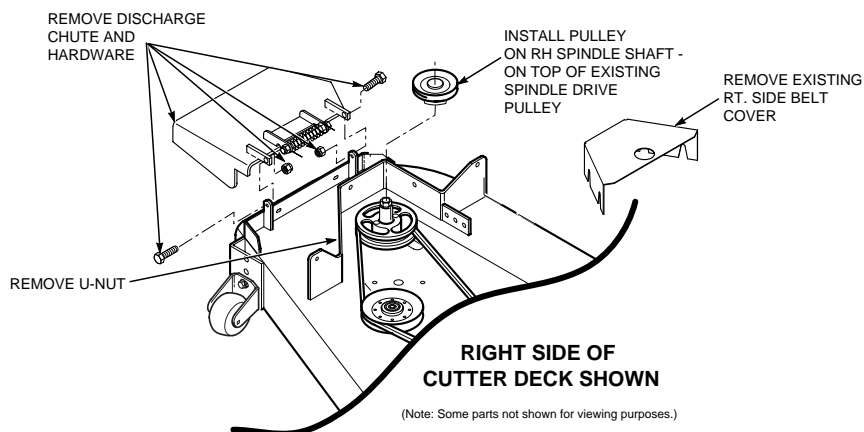

FIGURE 1

-NOTE-

There are two (2) pulleys supplied with this kit. Small pulley (3-3/4" O.D.) is for 48" deck. Large Pulley (4.0" O.D.) is for 52" deck.

4. Install the grass catcher pulley onto the spindle assembly. Apply loctite to both pulley setscrews and tighten. See Figure 1.
5. Install the blower mounting bracket to the deck using carriage bolts (p/n 04003-11), lockwashers, and nuts. Do not fully tighten the hardware at this time. See Figure 2, Page 3
6. Install the catch plate (p/n 423297) to the blower assembly using carriage bolts (p/n 04003-12) facing upward. Secure with lockwashers and elastic stop nuts. Do not fully tighten the hardware at this time. See Figure 3, Page 3.
7. Install the blower assembly to the mounting bracket and secure with the mounting pin. See Figure 3, Page 3.
8. Align the blower assembly with the discharge opening of the cutter deck. Tighten the hardware for the mounting bracket. Then tighten the hardware for the catch plate.

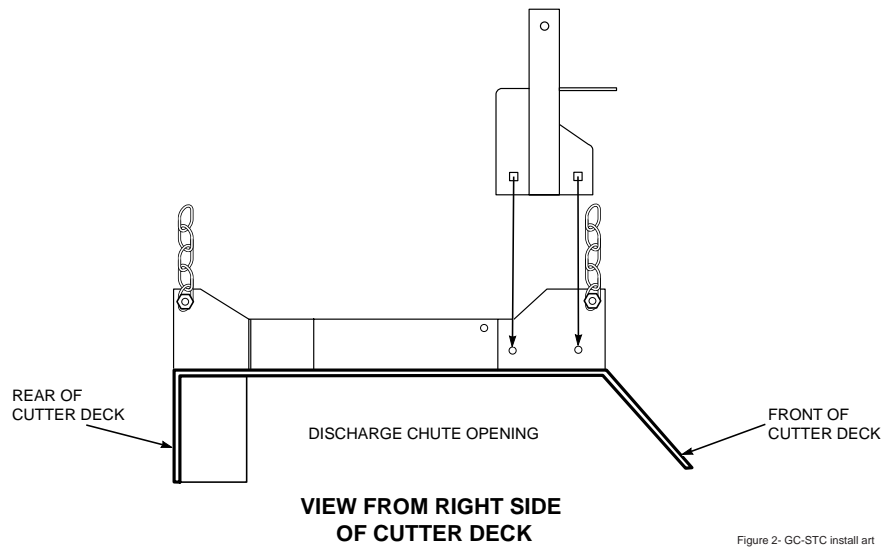

FIGURE 2

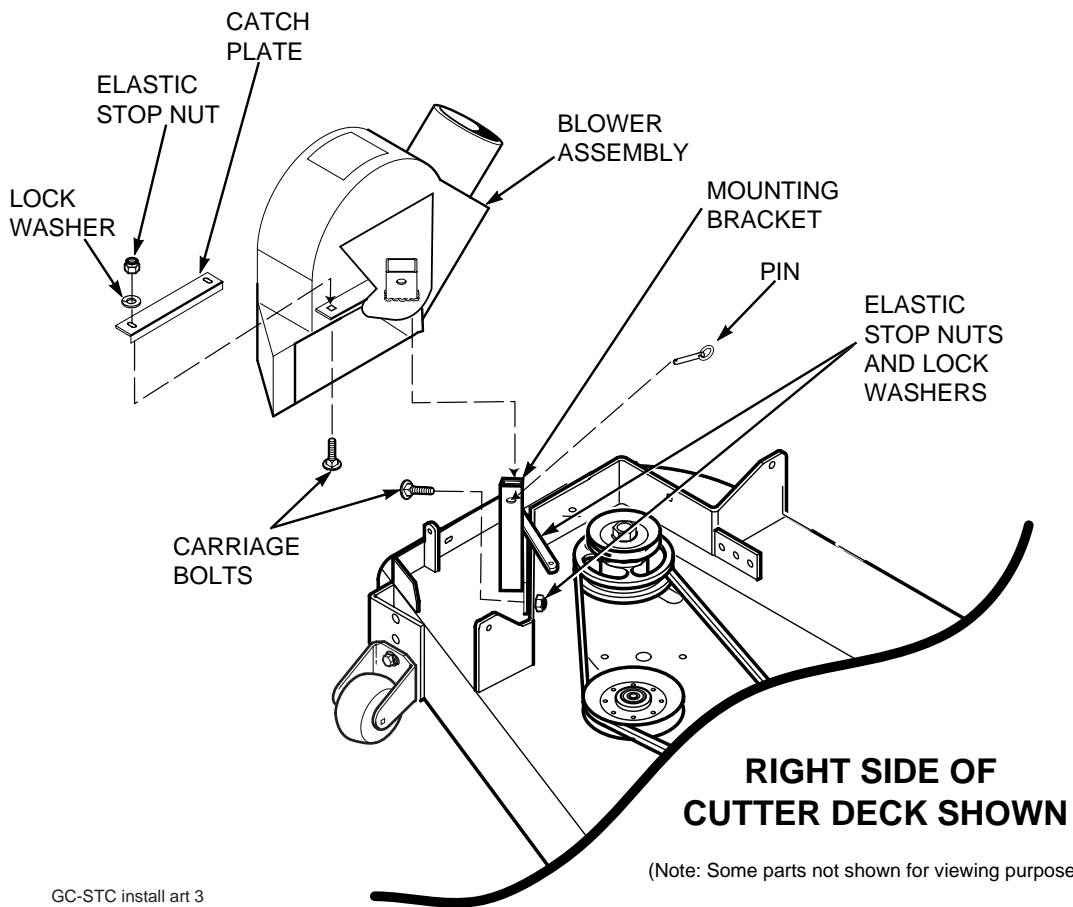
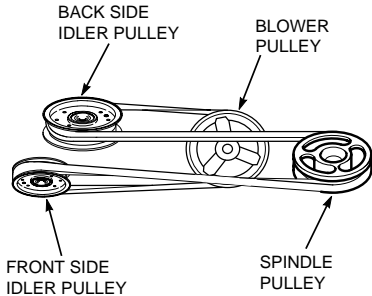

FIGURE 3

9. Install the belt to the spindle pulley. When replacing the belt, see figure below.



10. Install the new belt covers and secure. See items number 1 and number 21 on page 9 of the Blower Mounting Components section in the Illustrated Parts List for proper installation.

11. Install the hopper mounting brackets to the outside of the frame on the rear of the machine. See Figure 4.

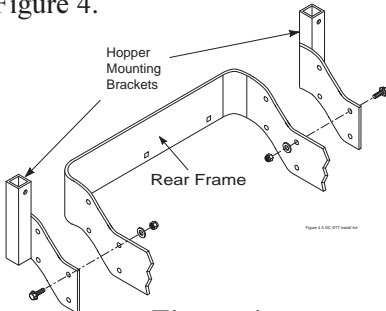

Figure 4

12. Attach the hood assembly to the machine by installing the mounting post into the hopper mounting brackets and secure with the ring pins. See Figure 5.

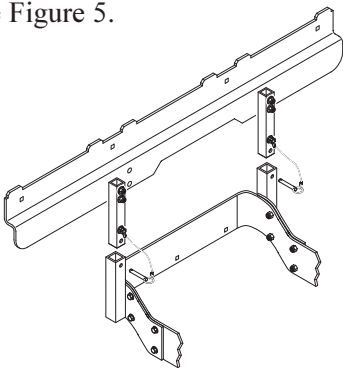

Figure 5

13. Install the hose from the blower assembly adapter to the hopper hood and secure using the 6-1/2" clamps.

14. Install the bag assemblies.

15. Using the weight support bar as a guide, identify the four corresponding mounting holes, and the existing hardware that will need to be removed in order to secure the weight support bar to the front of the machine as shown. See Figure 5-A.

16. Install one 7/16-14 x 1-3/4" hex head bolt into each of the four mounting holes in the weight support bar, and through the matching holes in the caster support weldment. Secure this assembly to the front of the machine using the 7/16- .5" x 1-1/4" x .083" flatwashers, and the 7/16-14 elastic stop nuts. Torque hardware to 59 ft. lbs. See Figure 5-A.

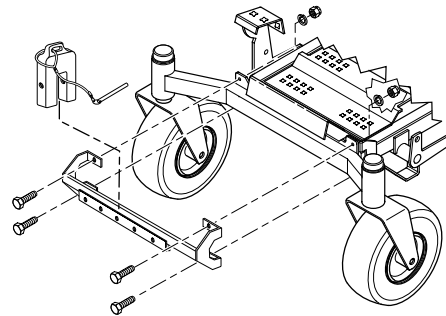

Figure 5-A

17. Operate and test.

4.1 GRASS CATCHER REMOVAL INSTRUCTIONS

1. Prepare the work area making sure that it is a clean, safe environment.
2. Remove the bag assemblies from the grass catcher.
3. Remove the rubber strap holding the adapter to the blower assembly. See Figure 6.
4. Remove the pin holding the blower assembly to the mounting bracket on the cutter deck and remove the blower assembly. See Figure 6.

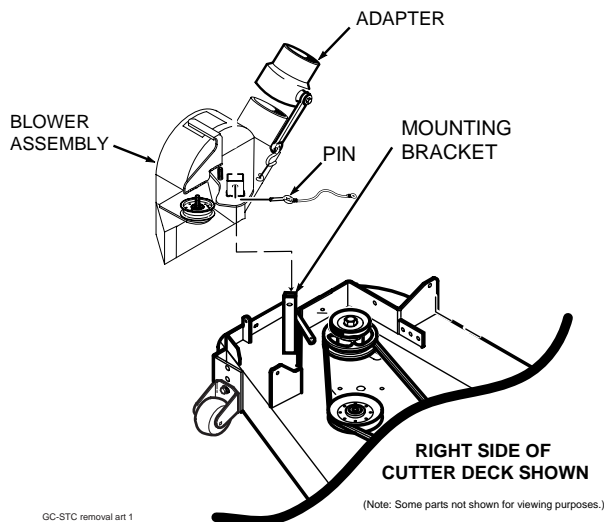

Figure 6

6. Remove the hood assembly.



7. Re-install the side discharge chute to the opening on the cutter deck. Replace the two outside mounting bolts on the discharge chute with the clevis pins (p/n 04064-15) and rue cotter pins (p/n 04069-03). See Figure 8.

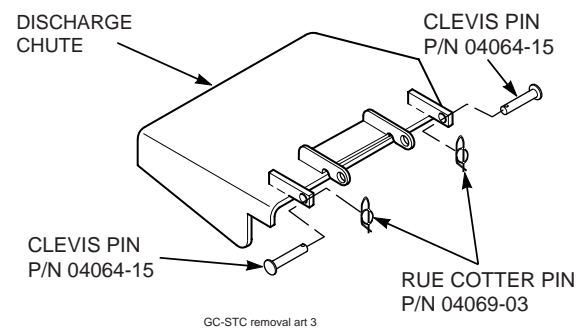

Figure 8

5. Remove the two (2) pins holding the hood assembly to the mounting posts on the rear of the machine. See Figure 7.

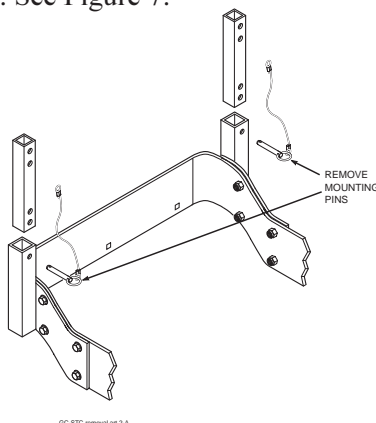
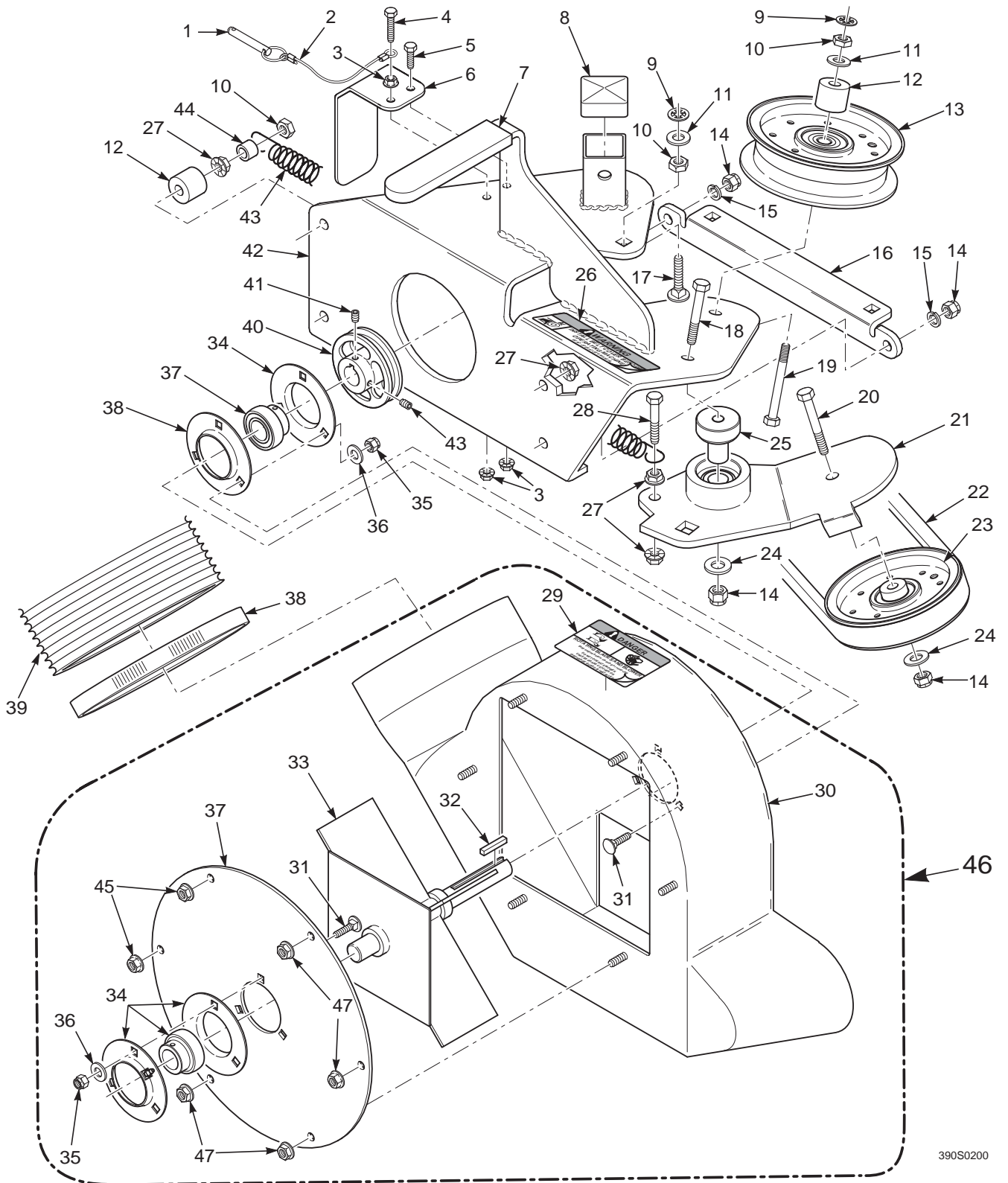

Figure 7

NOTES

GC-STC BLOWER HOUSING ASSEMBLY



390S0200

GC-STC BLOWER HOUSING ASSEMBLY

Ref. No.	Part Number	Description
1	04067-07	Pin, Ring 2-1/4" Long
2	481547	Lanyard, Deck Height Pin
3	04019-02	Nut, Serr. Flange 1/4-20
4	04001-59	Bolt, Hex Head 1/4-20 x 1-1/4"
5	04001-01	Bolt, Hex Head 1/4-20 x 3/4"
6	423298	Belt Cover, Rear
7	481428	Grip, Blower Lever
8	482300	Cap, Square
9	04024-02	Nut, Push On 3/8 Thread
10	04021-05	Lock Nut, 3/8-16
11	04041-07	Flatwasher, 3/8-.391 x .938 x .105
12	43277	Spacer
13	482299	Pulley, Idler 4" Dia.
14	04021-09	Nut, Elastic Stop 3/8-16
15	04030-04	Lockwasher, 3/8-16
16	423296	Plate, Catch Mounting
17	04003-05	Bolt, Carr. 3/8-16 x 1-1/2"
18	04001-46	Bolt, Hex Head 3/8-16 x 2-1/4"
19	04001-62	Bolt, Hex Head 3/8-16 x 3-1/4"
20	04001-45	Bolt, Hex Head 3/8-16 x 2"
21	461519	Idler Arm Weldment
22	482278	Belt, GC-STC
23	482079	Pulley, 4" O.D.
24	04043-04	Washer, 3/8 Hardened
25	43575	Pivot, Idler
26	481039	Decal, Belt Cover
27	04019-04	Nut, Serr. Flange 3/8-16
28	04001-136	Bolt, Hex Head 3/8-16 x 1-1/2 Gr. 8
29	482293	Decal, Danger
30	461342	Blower Housing Weldment, includes item #29
31	04003-12	Bolt, Carr. 5/16-18 x 3/4" Gr. 5
32	04063-06	Key, 1/4 x 1/4 x 1-1/2"
33	45491	Fan Weldment
34	48915	Bearing with Locking Collar
35	04021-10	Nut, Elastic Stop 5/16-18
36	04040-04	Flatwasher, 5/16-.344 x .688 x .065
37	421319	Cover, Blower Housing
38	48136-01	Clamp, 6-1/2" Max Dia.
39	48135-10	Hose, 6" Dia.
40	482298	Pulley, 4-3/4" O.D. - 1" Bore
41	04012-04	Set Screw, 5/16-18 x 3/8"
42	461343	Frame Weldment, Blower Mount
43	481522	Spring, Main Drive
44	43212	Spacer
45	04019-03	Nut, Serr. Flange 5/16-18
46	461341	Blower Housing Assembly

-Note-

Some of the hardware is common hardware and you may purchase it locally. Be sure that all bolts purchased locally are a grade 5.

GC-STC BLOWER MOUNTING COMPONENTS

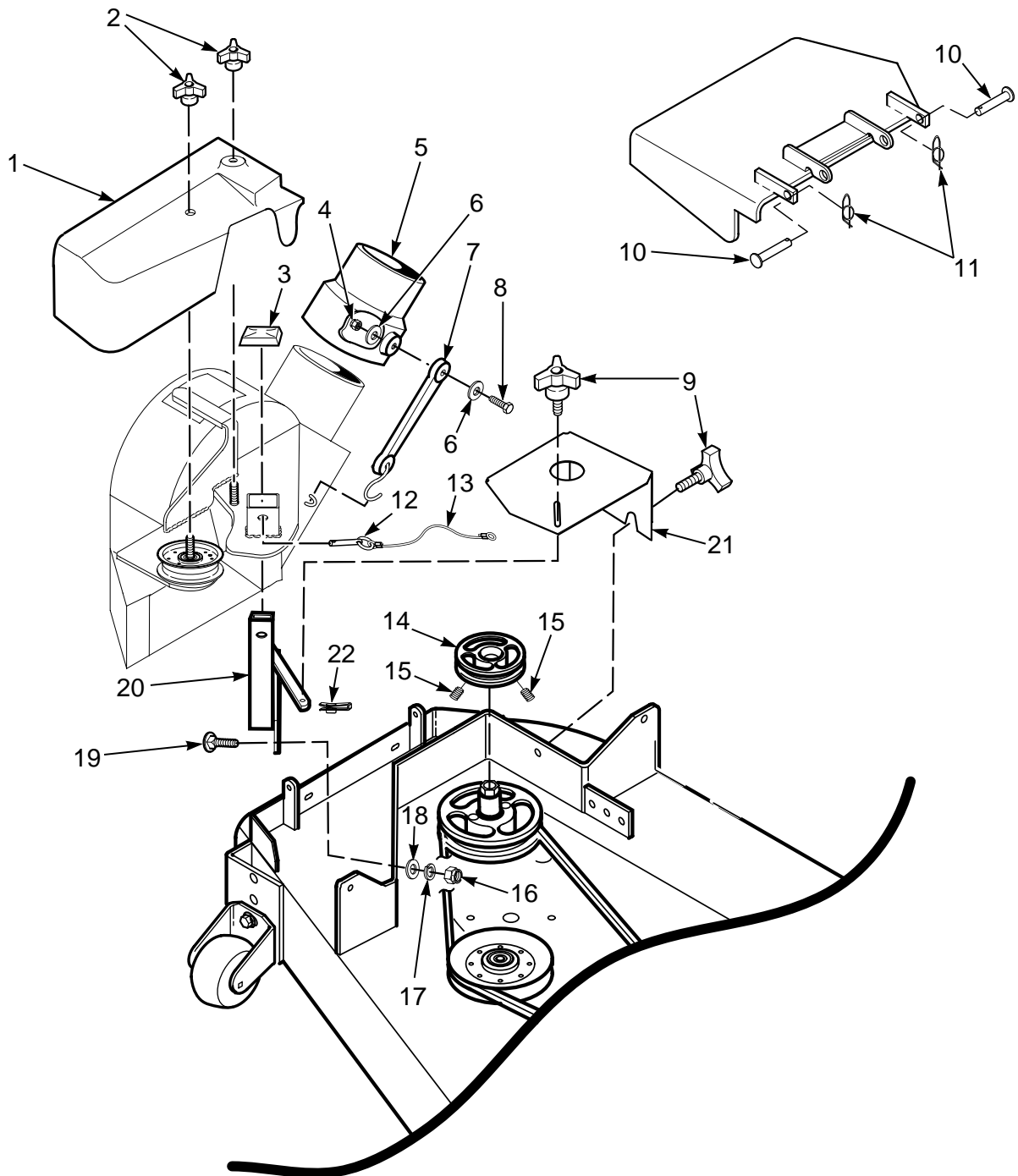

390S0203-A

GC-STC BLOWER MOUNTING COMPONENTS

Ref. No.	Part Number	Description
1	482612	Belt Cover, GC-STC
2	04029-04	Wingnut, Plastic 3/8 Small
3	482300	Cap, Square Vinyl
4	04021-08	Nut, Elastic Stop 1/4-20
5	461387	Adapter, Blower GC-STC, includes item #7
6	04040-14	Flatwasher, 1/4-.312 x .750 x .065
7	48137-04	Rubber Strap 7-3/4"
8	04001-59	Bolt, Hex Head 1/4-20 x 1-1/4"
9	481625-01	Knob W/Stud, 3/8-16 x 1-1/4"
10	04064-15	Clevis Pin, 5/16 x 1-1/2"
11	04069-03	Pin, Rue Cotter 5/16 Dia.
12	04067-07	Pin, Ring 1/2 x 2-1/4"
13	481547	Lanyard
14	482248	Pulley, 3-3/4" for 48" Deck
	482587	Pulley, 4.0" for 52" Deck
15	04012-04	Setscrew, 5/16-18 x 3/8"
16	04021-09	Nut, Elastic Stop 3/8-16
17	04030-04	Lockwasher, 3/8"
18	04041-07	Flatwasher, 3/8-.391 x .938 x .105
19	04003-11	Bolt, Carr. 3/8-16 x 1-1/4" Grade 5
20	461530	Mounting Post Weldment, Blower
21	423708	Belt Cover
22	04110-03	U-Nut

-Note-

Some of the hardware is common hardware and you may purchase it locally. Be sure that all bolts purchased locally are a grade 5.

GC-STC BUCKET SUPPORT COMPONENTS (UPPER)

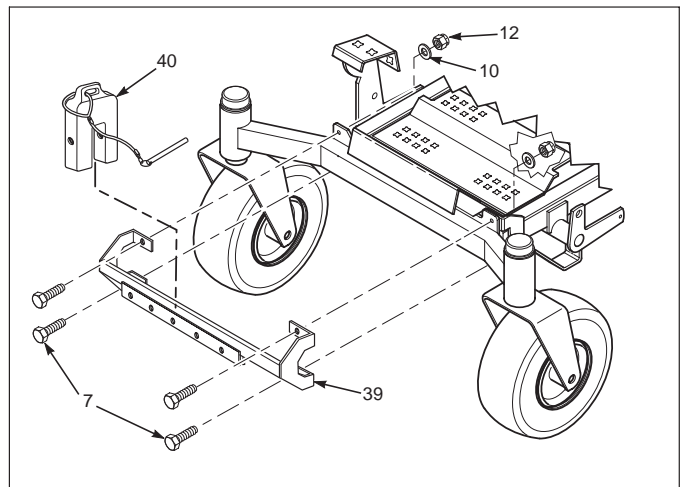
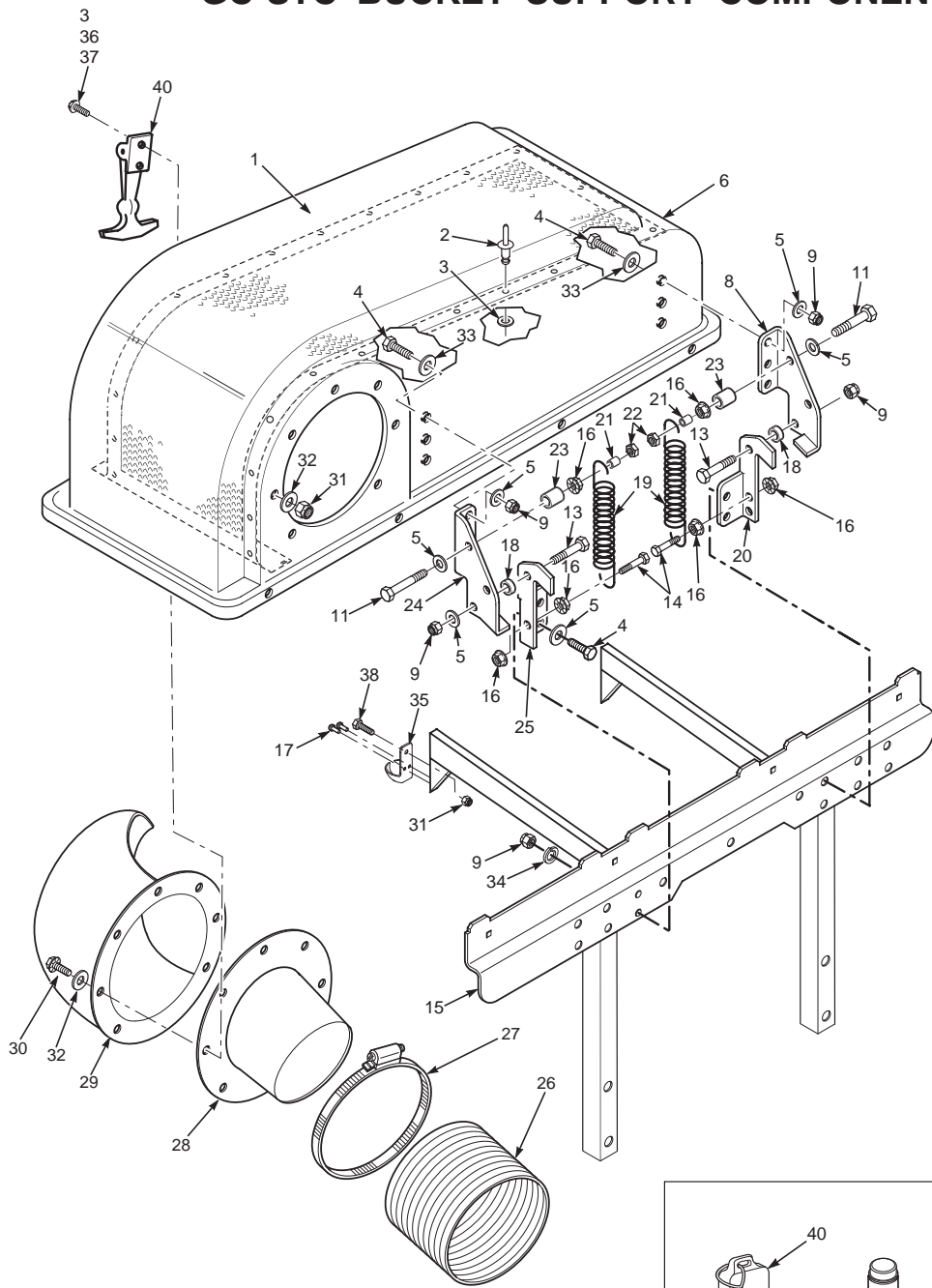



GC-STC BUCKET SUPPORT COMPONENTS (UPPER)

Ref. No.	Part Number	Description
1	423302	Screen, Catcher Hood
2	04090-02	Pop Rivet, 3/16 x .652
3	04041-19	Flatwasher, 3/16-.196 x .469 x .048
4	04001-32	Bolt, Hex Head 3/8-16 x 1-1/4"
5	04041-01	Flatwasher, 3/8-.391 x .938 x .105
6	461408	Hood Assembly, GC-STT (includes items 1, 2 & 3 and items 2 & 15 on page 14)
7	04001-117	Bolt, Hex Head 7/16-14 x 1-3/4"
8	423258	Hinge, Upper LH
9	04021-09	Nut, Elastic Stop 3/8-16
10	04040-11	Flatwasher, 7/16-.500 x 1-1/4"
11	04001-46	Bolt, Hex Head 3/8-16 x 2-1/4"
12	04021-11	Nut, Elastic Stop 7/16-14
13	04001-20	Bolt, Hex Head 3/8-16 x 1-1/2"
14	04001-135	Bolt, Hex Head 3/8-16 x 1-3/4" Grade 8
15	451516	Support Weldment, Bag Frame
16	04019-04	Nut, Serrated Flange 3/8-16
17	04090-03	Rivot, 3/16 x .402 POP
18	43546	Bushing, Hopper Pivot
19	482304	Spring, Hood Hinge
20	423436	Hinge, Lower LH
21	43212	Spacer
22	04021-05	Locknut, 3/8-16
23	43277	Spacer
24	423259	Hinge, Upper RH
25	423261	Hinge, Lower RH
26	48135-10	Hose, 6" Dia. x 49.5"
27	48136-01	Clamp, 6-1/2" Max Dia.
28	482269	Tube, Filler GC-STC
29	482268	Elbow, GC-STC
30	04001-10	Bolt, Hex Head 5/16-18 x 1-1/4"
31	04021-10	Nut, Elastic Stop 5/16-18
32	04040-15	Flatwasher, 5/16-.375 x .875 x .083
33	04041-11	Flatwasher, 3/8-.406 x 1-1/2" x .179
34	04030-04	Lockwasher, 3/8 Spring
35	482409	Latch
36	04010-25	Screw, #10-32 x 3/4"
37	04021-01	Nut, Elastic Stop #10-32
38	04001-08	Bolt, Hex Head 5/16-18 x 3/4"
39	451517	Support Weldment, Weights
40	461097	Weight Assembly

-Note-

Some of the hardware is common hardware and you may purchase it locally. Be sure that all bolts purchased locally are a grade 5.

GC-STC BUCKET SUPPORT COMPONENTS (LOWER)

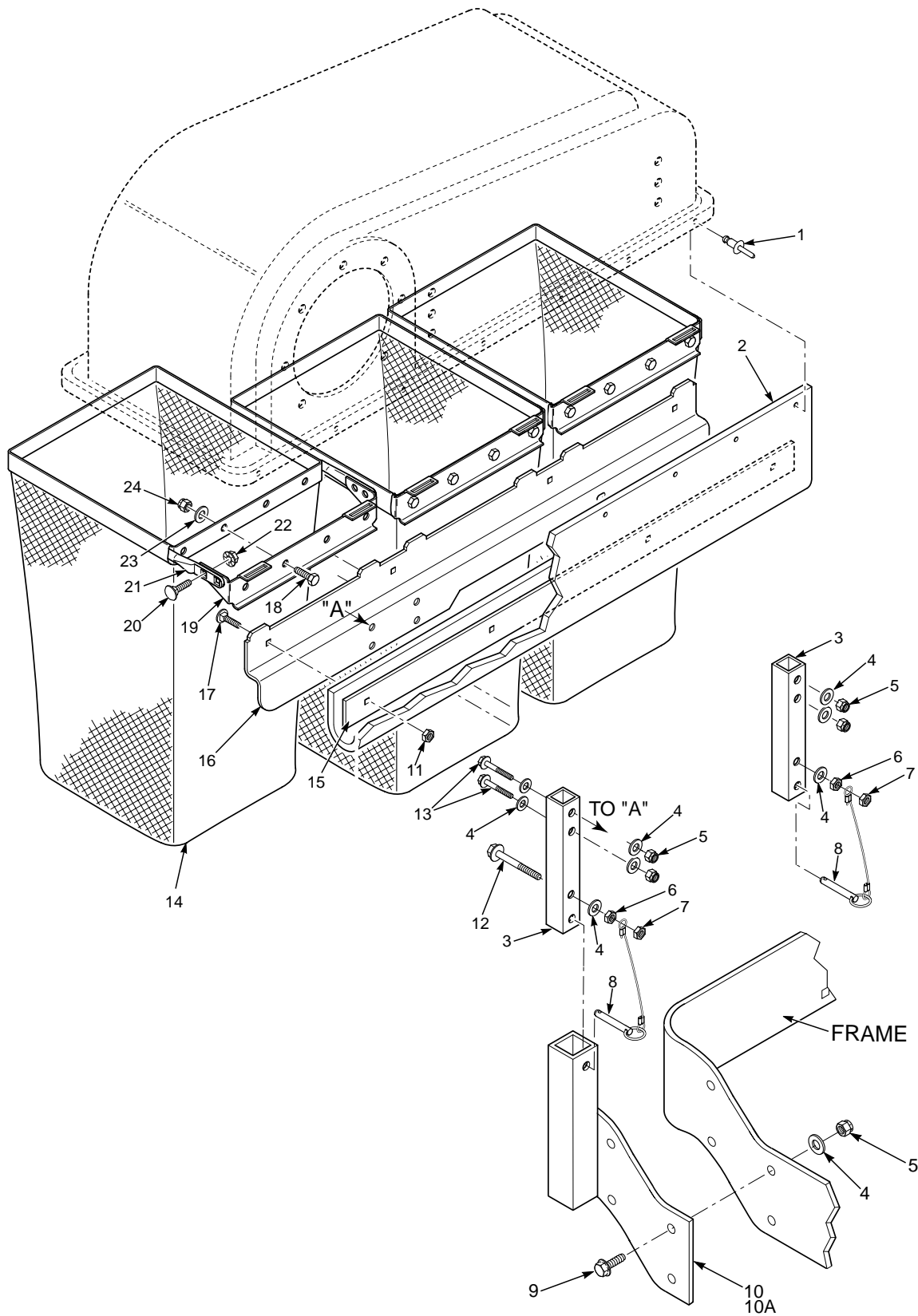

STC 2002 BSC

GC-STC BUCKET SUPPORT COMPONENTS (LOWER)

Ref. No.	Part Number	Description
1	04090-02	Pop Rivet, 3/16 x .652
2	482321	Seal, Hood
3	423262	Tube, Upright
4	04041-07	Flatwasher, 3/8-.391 x .938 x .105
5	04021-09	Nut, Elastic Stop 3/8-16
6	04020-04	Nut, 3/8-16
7	04021-05	Hex Lock Nut, 3/8-16
8	04067-07	Pin, Ring 1/2 x 2-1/4"
9	04001-19	Bolt, Hex Head 3/8-16 x 1"
10	451514	Mounting Bracket Weldment R.H
10A	451513	Mounting Bracket Weldment L.H.
11	04021-02	Lock Nut, 1/4-20 Center
12	04001-46	Bolt, Hex Head 3/8-16 x 2-1/4"
13	04001-31	Bolt, Hex Head 3/8-16 x 2-1/2"
14	482567	Bag Assembly, GC-STC
15	423312	Retainer, Seal
16	451516	Support, Bag Frame
17	04003-02	Bolt, Carr. 1/4-20 x 3/4"
18	04001-08	Bolt, Hex Head 5/16-18 x 3/4"
19	423198	Mount, Bag Frame Tube
20	04003-12	Bolt, Carr. 5/16-18 x 3/4"
21	423197	Tube, Bag Support
22	04019-03	Nut, Serr. Flange 5/16-18
23	04040-15	Flatwasher, 5/16-.375 x .875 x .083
24	04021-10	Nut, Elastic Stop 5/16-18

-Note-

Some of the hardware is common hardware and you may purchase it locally. Be sure that all bolts purchased locally are a grade 5.

GC-STC DECALS



481039

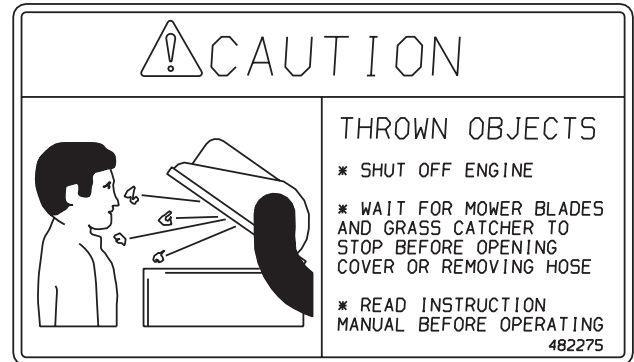

482275

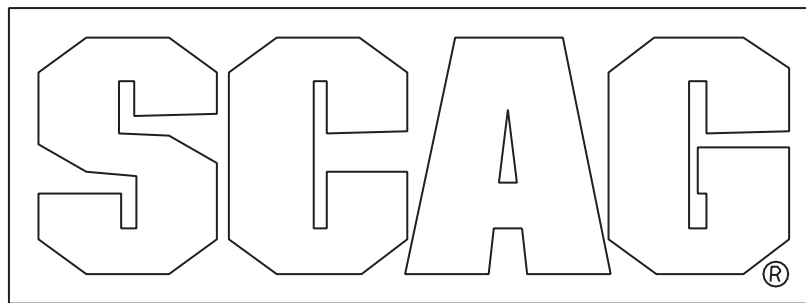

481327

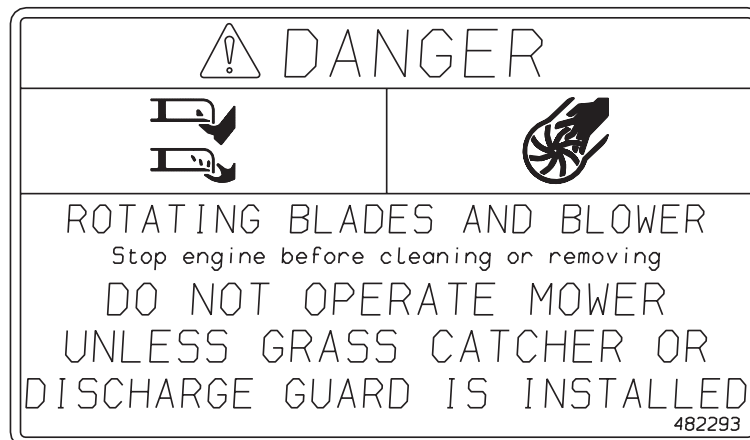

482293

LIMITED WARRANTY- COMMERCIAL ACCESSORY

Any part of the Scag commercial accessory manufactured by Scag and found, in the reasonable judgment of Scag, to be defective in material or workmanship, will be repaired or replaced by an Authorized Scag Service Dealer without charge for parts and labor.

The Scag accessory, including any defective part, must be returned to an Authorized Scag Service Dealer within the warranty period. The expense of delivering the accessory to the dealer for warranty work and the expense of returning it back to the owner after repair or replacement will be paid for by the owner. Scag's responsibility in respect to claims is limited to making the required repairs or replacements, and no claim of breach of warranty shall be cause for cancellation or rescission of the contract of sale of any Scag machine. Proof of purchase will be required by the dealer to substantiate any warranty claim. All warranty work must be performed by an Authorized Scag Service Dealer.

This warranty is limited to 90 days from the date of original retail purchase for any Scag accessory that is used for commercial purposes, or any other income-producing purpose including rental use.

This warranty does not cover any accessory that has been subject to misuse, neglect, negligence, or accident, or that has been operated in any way contrary to the operating instructions as specified in the Operator's Manual. The warranty does not apply to any damage to the accessory that is the result of improper maintenance, or to any accessory or parts that have not been assembled or installed as specified in the Operator's Manual.

The warranty does not cover any accessory that has been altered or modified. In addition, the warranty does not extend to repairs made necessary by normal wear, or by the use of parts or accessories which, in the reasonable judgment of Scag, are either incompatible with the Scag mower or adversely affect its operation, performance or durability. This warranty does not cover engines and electric starters, which are warranted separately by their manufacturer.

Scag Power Equipment reserves the right to change or improve the design of any accessory without assuming any obligation to modify any accessory previously manufactured.

All other implied warranties are limited in duration to the 90 day warranty period. Accordingly, any such implied warranties including merchantability, fitness for a particular purpose, or otherwise, are disclaimed in their entirety after the expiration of the appropriate ninety day warranty period. Scag's obligation under this warranty is strictly and exclusively limited to the repair or replacement of defective parts and Scag does not assume or authorize anyone to assume for them any other obligation. Some states do not allow limitations on how long an implied warranty lasts, so the above limitation may not apply to you.

Scag assumes no responsibility for incidental, consequential or other damages including, but not limited to, expense for gasoline, oil, expense of delivering the machine to an Authorized Scag Service Dealer and expense of returning it back to the owner, mechanic's travel time, telephone or telegram charges, rental of a like product during the time warranty repairs are being performed, travel, loss or damage to personal property, loss of revenue, loss of use of the mower, loss of time, or inconvenience. Some states do not allow the exclusion or limitation of incidental or consequential damages, so the above limitation or exclusion may not apply to you.

This warranty gives you specific legal rights, and you may also have other rights which vary from state to state.

© 2003
SCAG POWER EQUIPMENT
DIVISION OF METALCRAFT OF MAYVILLE, INC
WWW.SCAG.COM

PART NO. 03125
PRINTED 6-2002
PRINTED IN USA